

# Panasonic

## THERMO VENTILATOR (BATHROOM DRYER)

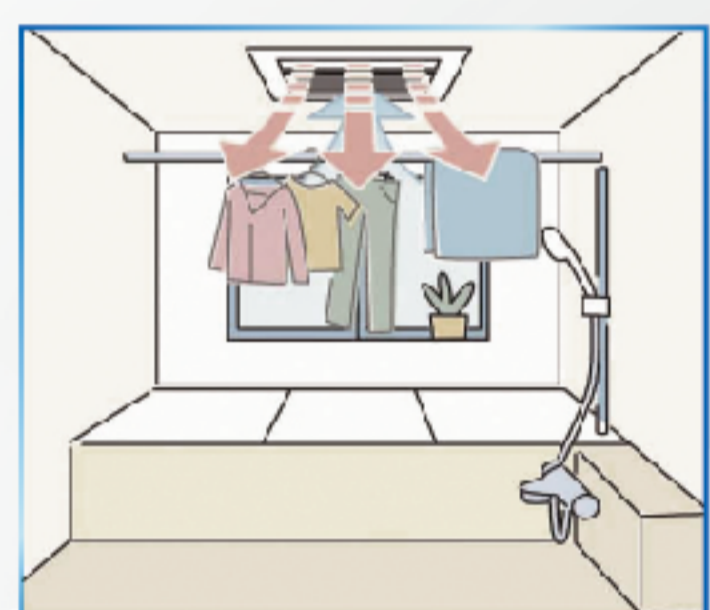

### CLOTHES DRYING

Dry your clothes by simply hanging in the bathroom

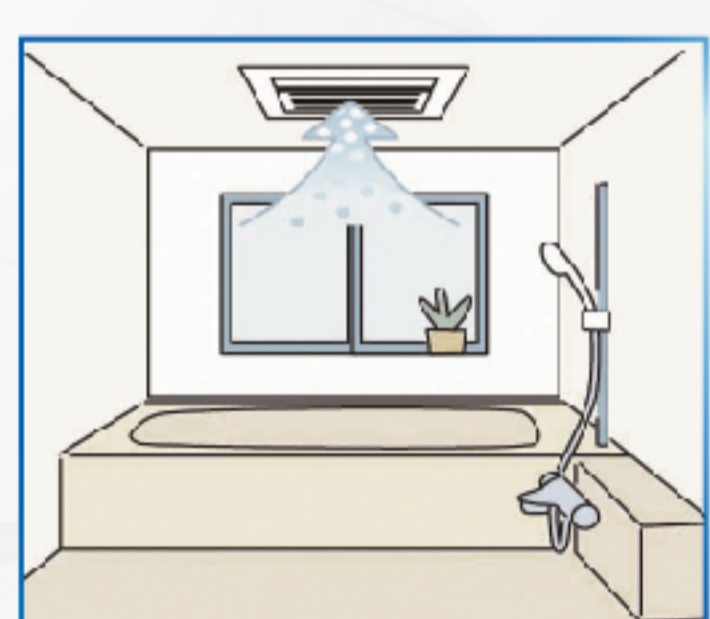

### VENTILATION

Exhausts smell & moisture for fresh environment

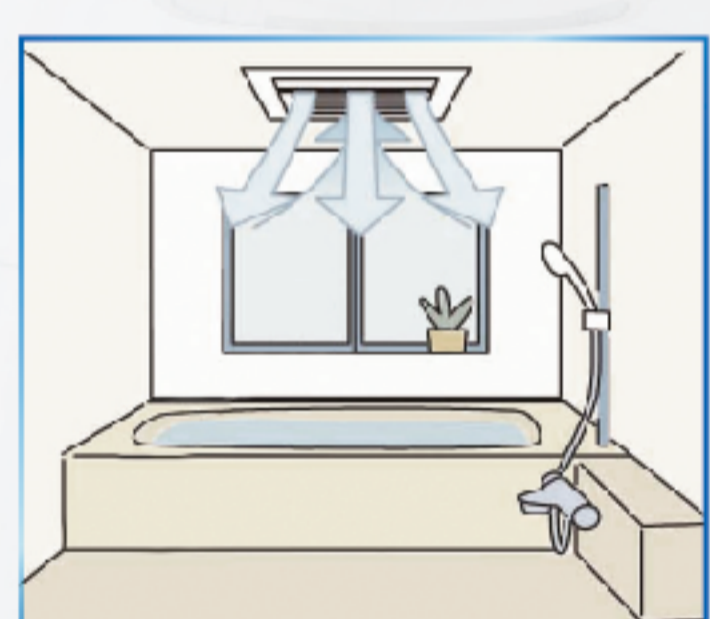

### CIRCULATION

Provides circulation of air to avoid uncomfortable feeling due to stagnant air

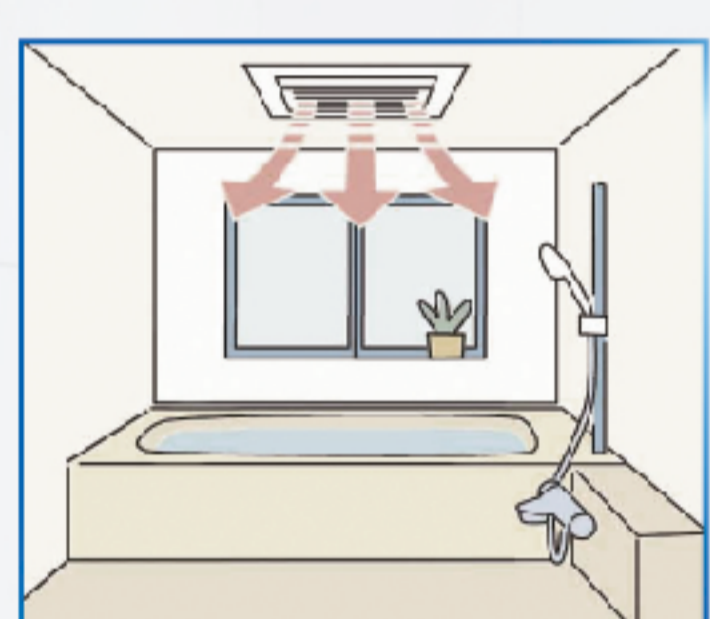

### HEATING (Instant Heat)

Let you enjoy warm & better comfort level during bath



### An Integrated Ventilator with Multi-functions

The ventilator possesses 4 functions, clothes drying, ventilation, air circulation and heating, in one unit. It can save the space from storing individual products of different functions.



**FV-30BG3**



# FEATURE

## Reliable

Multi-level safety structure provides safety protection for you and your family, as well as your property from any accidents.

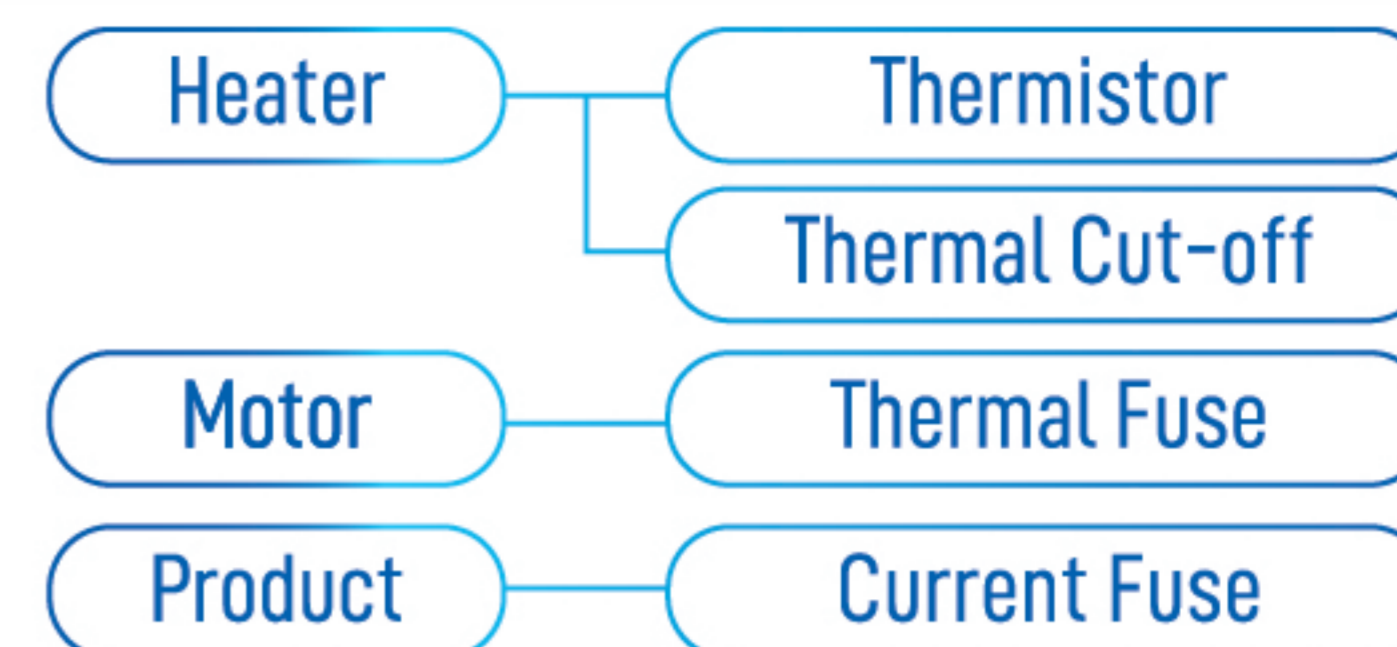

## Convenient

All functions can be operated through the handheld wireless remote control. The control unit complies with IPX4 protection for water ingression in case spraying by water accidentally.

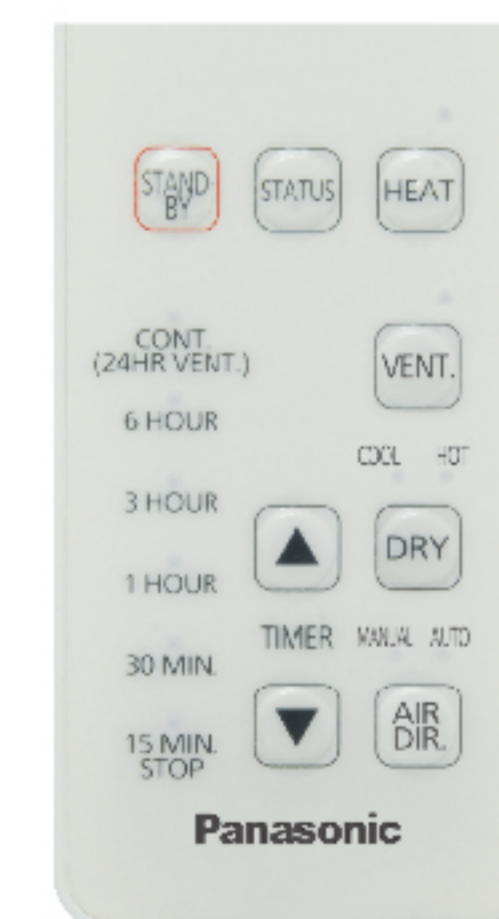

## Health Considerate

The ventilator is equipped with "Super alleru-buster filter", which purifies the air inside the bathroom that maintains a healthy and clean environment to you.



You can keep the bathroom dry by using the "Dry" function to prevent mold grow in the moist space.

## PERFORMANCE CHART

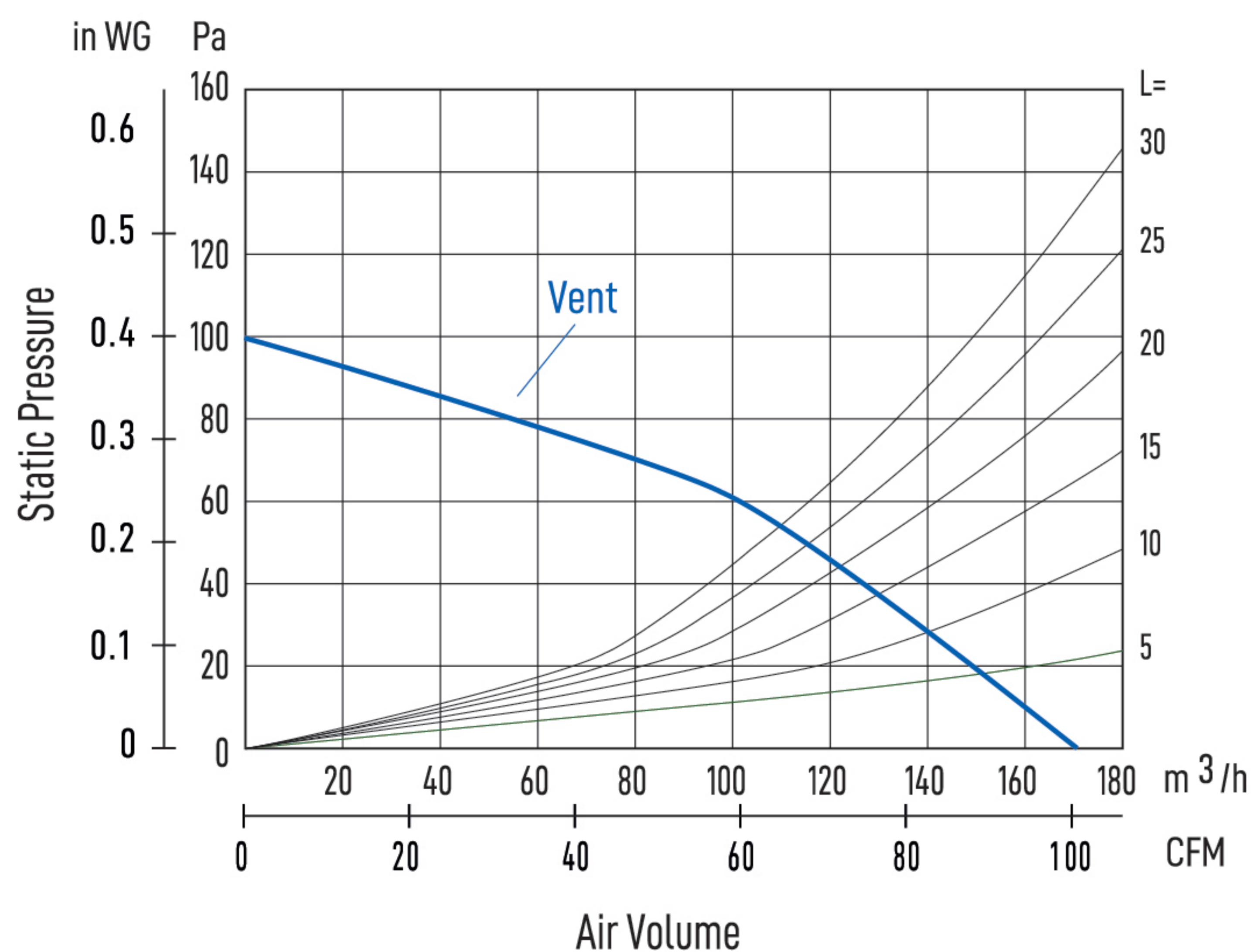

## DIMENSION (Unit: mm)

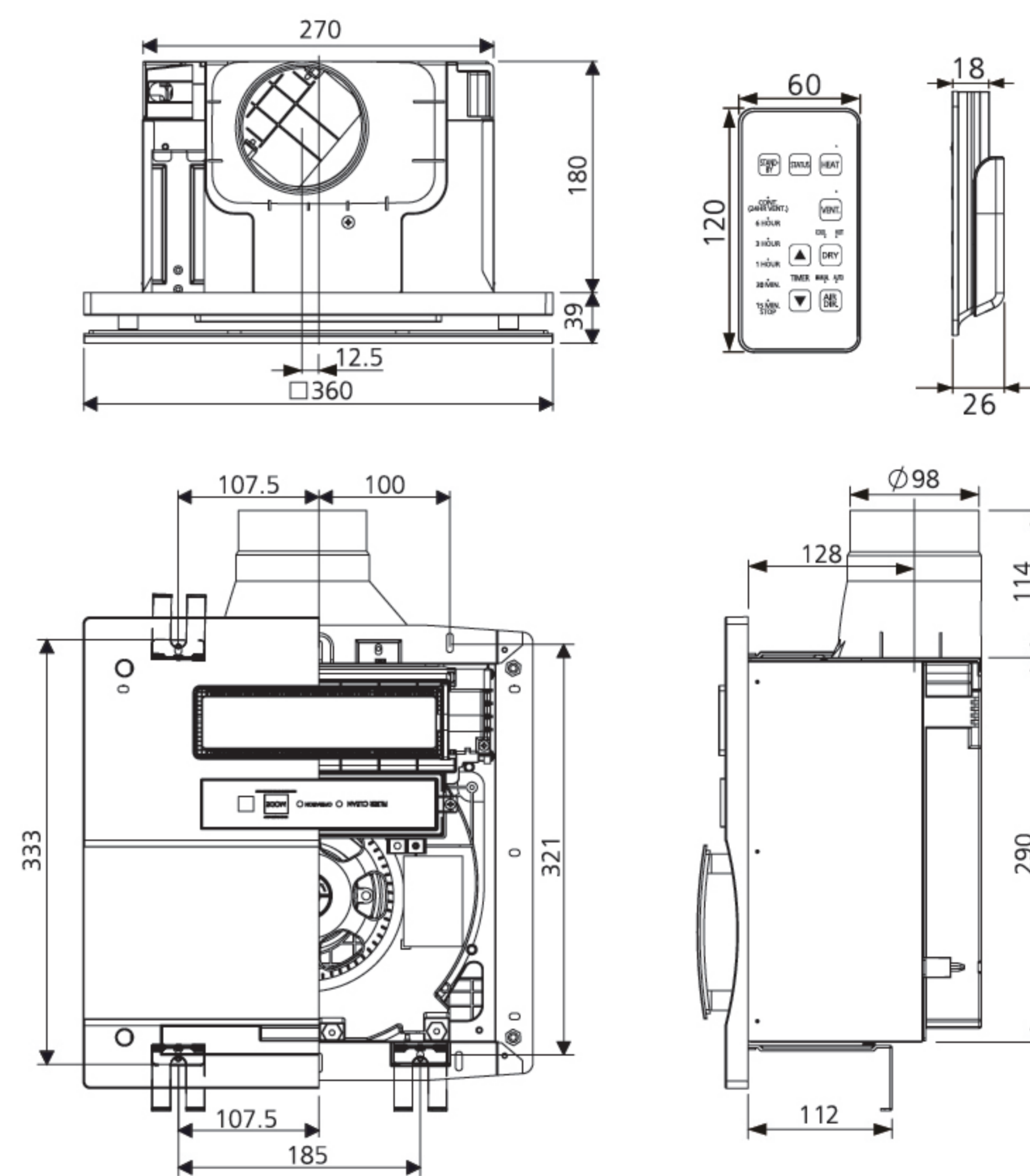

## SPECIFICATION

Model No.	Rated Voltage [V]	Rated Frequency [Hz]	Rated Current [A]	Ventilation [m³/h]	Power Consumption [W]		Noise [dB]			Weight [kg]
					Heat	Vent	Heat	Dry	Vent	
FV-30BG3	220	50	6.8	170	1500	28	46	46	39	5.0

**Panasonic**<sup>®</sup>

Panasonic Ecology Systems Co., Ltd.  
<http://www.plshk.panasonic.hk/>

- Actual colors may vary slightly from shown.  
 - Specifications are subject to change without prior notice.

CATALOG NO: P-BD005  
 Printed in Hong Kong 06.20